

ALMACRAWLER

ATHENA 1490

CRAWLER SELF-LEVELLING SCISSOR LIFT



PRIMO

EVO



1800 025 024
monitor.net.au

SELF-PROPELLED BI-LEVELLING

The innovative ATHENA 1490 self-propelled tracked scissor lift with patented self-levelling technology overcomes the standard limitations of traditional equipment.

With a working height of 14m (46'), a load capacity of 400kg (881 lbs) and self-levelling up to +/-15°, the ATHENA 1490 is designed for safety and productivity on the jobsite.

L'innovativa piattaforma a forbice cingolata semovente ATHENA 1490 con tecnologia autolivellante brevettata supera i limiti standard delle piattaforme tradizionali.

Con un'altezza di lavoro di 14 m, una capacità di 400 kg e autolivellamento fino a +/-15°, la ATHENA 1490 è progettata per garantire sicurezza e produttività.



14m 46'
working
height
altezza lavoro

9.2m 30'
travel
height
altezza traslazione



AES
ANTI-ENTRAPMENT
SYSTEM



Radio console
by AUTECH

FORKLIFT POCKETS
Tasche per le forche del muletto

ATHENA 1490 PRIMO

**REMOVABLE
BATTERY
PACK**

only on the PRIMO



ATHENA 1490 EVO

**EVO
DIESEL**

Yanmar Engine 3TNV-74F



| Technical data | EVO | PRIMO | Dati tecnici |
|---|---------------------------------------|---|---|
| Basket capacity | 400 kg (2 op.) 881 lbs (2 op.) | | Portata in navicella |
| Basket size | 2.32 x 1.57 m 7'-7" x 5'-2" | | Dimensione navicella |
| Max working height | 14 m 46' | | Altezza max di lavoro |
| Max height basket floor | 12 m 39' | | Altezza max calpestio |
| Moving height | 9.2 m 30' | | Altezza di traslazione |
| Undercarriage | Bi-Levelling | | Sottocarro |
| Basket levelling | Automatic | | Livellamento navicella |
| Longitudinal levelling Front | +/- 15° | | Livell. longitudinale anteriore |
| Longitudinal levelling Rear | +/- 15° | | Livell. longitudinale posteriore |
| Lateral levelling | +/- 14° | | Livell. laterale |
| Speed | max 2.5 km/h 1.55 mph | max 4 km/h 2.48 mph | Velocità |
| Gradeability | 25° | | Pendenza superabile |
| Side slope | 21° | | Massima pendenza laterale |
| Length | 3.02 m 9'-11" | 2.88 m 9'-5" | Lunghezza |
| Width | 1.69 m ÷ 2.03 m 5'-6" ÷ 6'-8" | | Larghezza |
| Min height with narrow tracks folded railings | 2.86 (2,54) m 9'-5" ÷ 8'-4" | | Altezza min ringhiere ripiegate con cingoli stretti |
| Min height with wide tracks folded railings | 2.48 (2,16) m 8'-2" ÷ 7'-1" | | Altezza min ringhiere ripiegate con cingoli larghi |
| Compliance | EN 280, ANSI, CSA, AS/NZS | | Conforme |
| Main Power Source | Yanmar engine 3TNV-74F Diesel 14kW | LTH Power Pack 420Ah - 48V | Alimentazione principale |
| Electric motors | No | N°2 electric motors Total Power 15 kW | Motori elettrici |
| Battery charger | No | Automotive battery charger 85-265VAC 50/60Hz (automatic settings) | Caricabatterie |
| Total weight | 5250 Kg 11574 lbs | 5200 Kg 11464 lbs | Peso totale |
| Non-marking tracks | Optional | | Cingoli anti-traccia |

ATHENA 1090 PRIMO

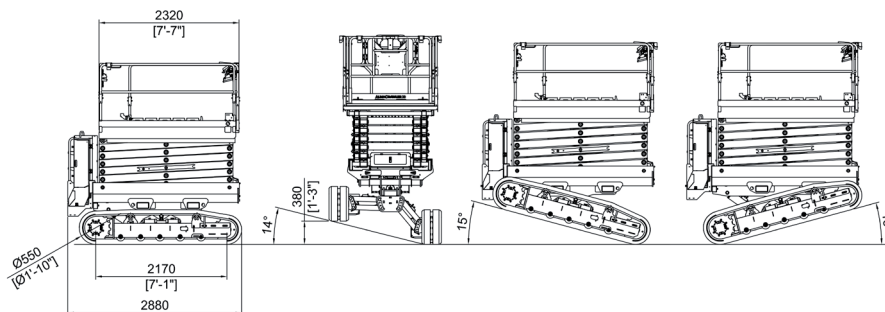

ATHENA 1490 EVO

