

monitor

the world's
best equipment
supported
locally

Sales | Service | Parts | Hire | Finance

Monitor 10 Vertical Mast Lift

1800 025 024
monitor.net.au

@MonitorAUS



V1.0 - 241206



MONITOR 10



9.6M
WORKING HEIGHT

Innovative self-propelled AWP on crawlers with automatic stabilization, to allow the operations on uneven grounds, as good different option to SPIDER lifts.

The Monitor 10 Vertical Mast Lift is an 9.6 m light equipment, towable with light trailers with a capacity of 230 kg. It is powered by diesel engine only for outdoor use, or available bi-energy with the additional 230 Vac electric motor for indoor purpose.

The Monitor 10 is easy to use, rigid and so able to work in the narrowest places. The crawlers and so the steering let the machine turn on itself. The automatic stabilization allows the levelling on any slope, so the user is only focusing on the operation of the upper part.

It is perfect for maintenance job, painting activity, windows cleaning, and tree care business. Inside the building it is suitable for any job, the light weight doesn't damage even the most delicate floor, and so the terraces and attics.





Technical Specifications

Working diagram on crawlers

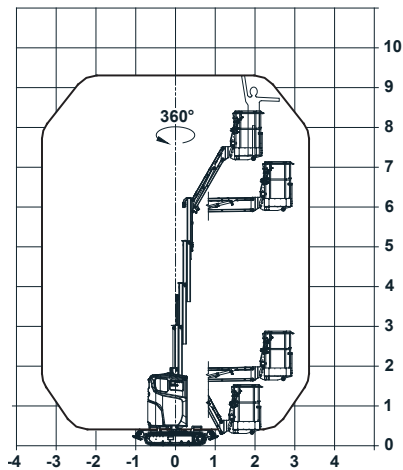

Working diagram on stabilizers

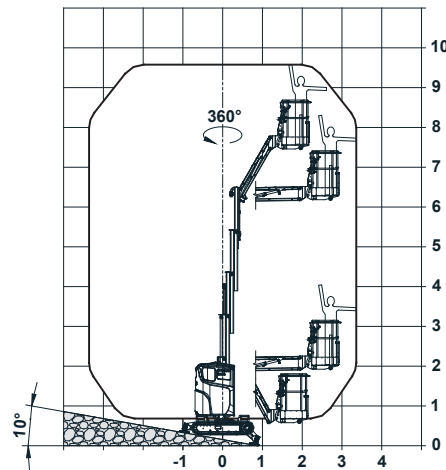

INDOOR

160 kg
70 kg
TOT. 230 kg
 Wind max 0 km/h
 Manual Force max. 400N

OUTDOOR

80 kg
150 kg
TOT. 230 kg
 Wind max 45 km/h
 Manual Force max. 200N

Max working height	9.60 m
Max platform height	7.60 m
Max horizontal outreach	3.45 m
Max rated capacity	230 kg
Weight	2750 kg
Turret radius inside/outside	0 / 1,21
Basket Rotation (Optional)	± 70
Turret Rotation	± 180
Ground pressure in tracks	1,9 kg/cm ²
Ground pressure on stabilizer	2,4 kg/cm ²
Max slope	19° (35%)
Max working tilt x/y	3° (5,25%)
Standard engine	9.9 kW / 13 Hp
Optional engine	
Max speed stowed	2.8 km/h
Max speed not stowed	1 km/h

(All specs E&OE and subject to change)

Max. tilt for selfstabilizers

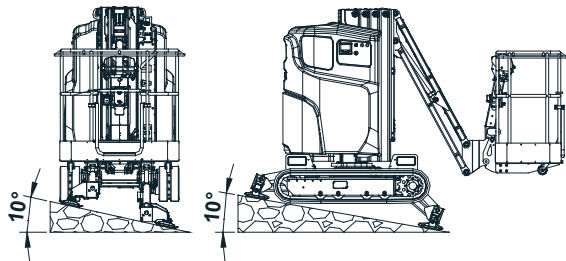

Jib free when machine stowed

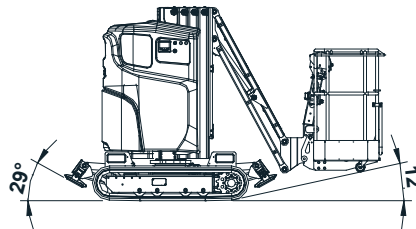

Max. slope 35%

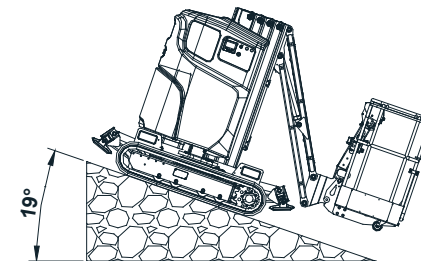





zero
downtime
guarantee*



Our Locations

Branches & Service Centres



Tamworth

143 Gunnedah Rd
Tamworth NSW 2340



Sydney

49-50 Cassola Pl
Penrith NSW 2740



Melbourne

24-28 William Rd
Dandenong South VIC 3175



Brisbane

191 Magnesium Dr
Crestmead QLD 4132



Brisbane - Caboolture

2 Alta Road
Caboolture QLD 4510



Perth

11 Reihill Rd
Maddington WA 6109



agent@monitor.net.au

1800 025 024
monitor.net.au

@MonitorAUS



monitor

the world's best equipment supported locally

Monitor 10 Vertical Mast Lift

7