

monitor LiFTS

SYDNEY MELBOURNE BRISBANE TAMWORTH

monitor.net.au • 1800 025 024



MONITOR RR19/500 RAIL BOOM LIFT



RAIL BOOM LIFTS



MONITOR RR19/500

The Monitor RR19/500 is designed to take you above and beyond construction on issues for rail—with a greater reach and load capacity. It also comes equipped with better features to ensure safety, and work efficiency.

This telescopic rail boom lift, developed by Platform Basket, is the bigger version of the famous RR14.

The Monitor RR19/500 is extremely rigid, and safe to accommodate 3 persons with a maximum weight capacity of 500kg.

Weighing just 19.5 t, the Monitor RR19/500 has a vertical outreach of up to 19m, and horizontal outreach of 14m.

With its self-levelling turret feature, working on tracks with a cant up to 200mm is now possible whilst ensuring the work platform is level at all times.

Powered by a 55 kW engine, or fully electric operation with lithium-ion batteries in order to make the equipment suitable for use in tunnels, subways and indoors.

19M
WORKING HEIGHT



OPTIONAL ADD-ONS:



Lithium
Battery



Measurement
Pantograph



The Monitor RR19/500 in almost full stretch!



TECHNICAL SPECIFICATIONS

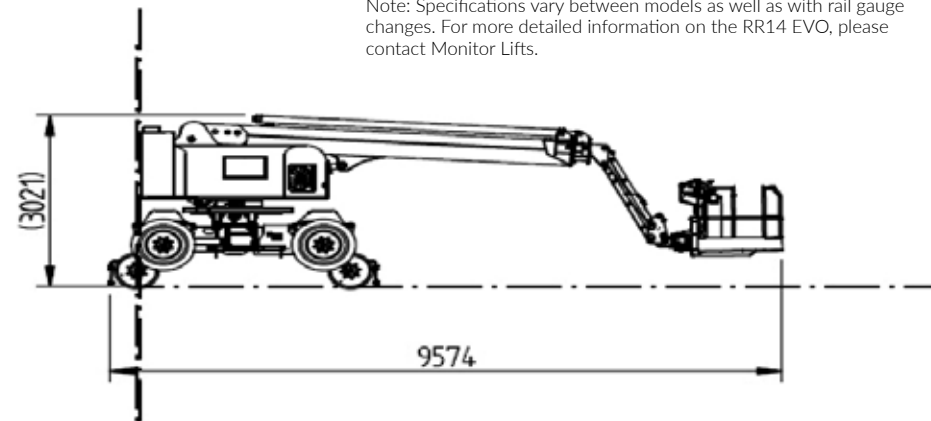
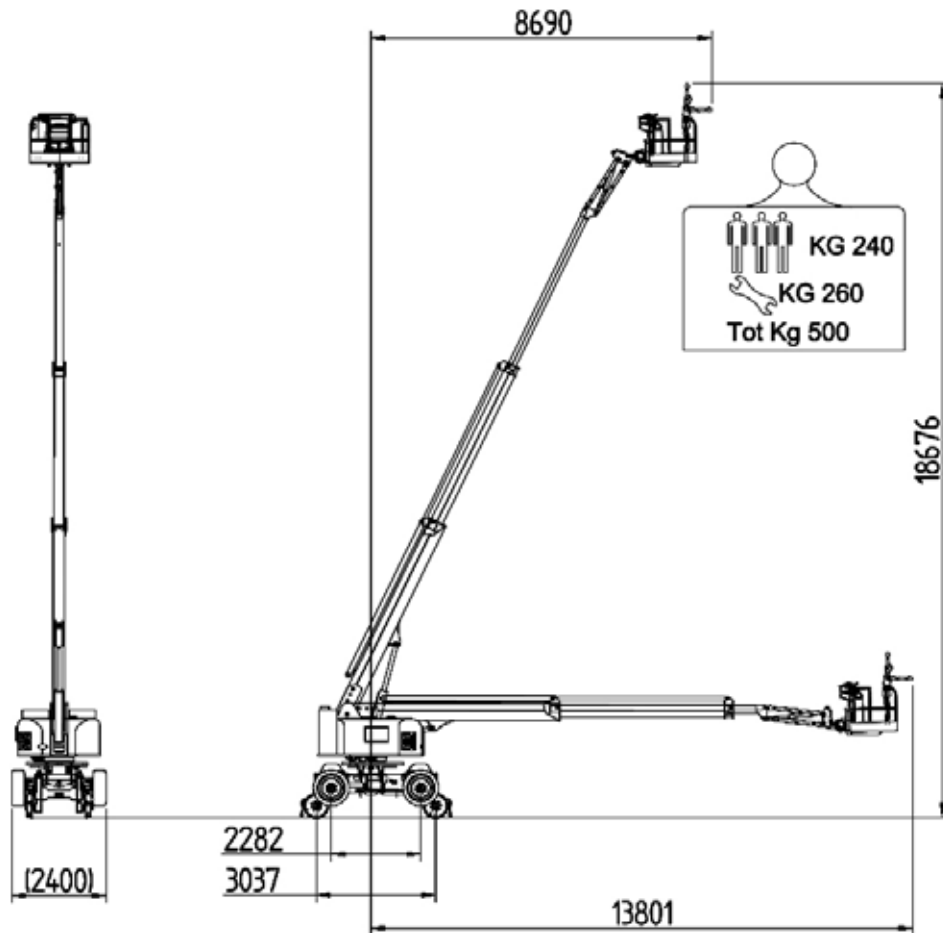

Max working height	19 m
Max working height in narrow set	17 m
Max horizontal outreach	14 m
Max. rated capacity	3 persons / 500 kg
Weight (approx)	19,500 kg
Turret rotation	360°
Basket rotation	deg 90° + 90°
Ground pressure driving (approx)	kN/m ²
Traffic load (live load) travelling	kN/m ²
Auto levelling turret	Std
Gradeability lengthwise	
Gradeability sideways	
Standard power source	Hatz 48 Hp Diesel
Optional power source	Emergency Hatz 9 Hp Diesel
Dual power options	Hybrid w/ Lithium Batteries
Tri-gauge	Optional
Drive Speed	Rail 14 km/h (Road 5 km/h)
Electric emergency lowering	Std

(All specs E&OE and subject to change)

Note: Specifications vary between models as well as with rail gauge changes. For more detailed information on the RR14 EVO, please contact Monitor Lifts.



MAX.500Kg=|||+260kg

4x4x4

The Monitor RR19/500's 3-person/ 500 kg-capacity basket upclose!



OPTIONAL ACCESSORIES

Lithium Battery

With a more efficient technology that is environment friendly with the reduction of noise and emissions, and increased safety.

It boasts a fully electric solution that enables it to be used in any situation—including operating inside a tunnel—with low noise, and no emissions.



Measurement Pantograph

Designed to fit to the RR19/500, it is very compact in size to maximize the machine's employability, with reduction of 3m to the total stowed height position.

This enables the machine to be transported on trucks without having to remove the pantograph.



GET IN TOUCH

You may contact us at monitor.net.au, or call us via our toll-free number at 1800 025 024.

RR19/500 **RAIL
BOOM**

