

monitor

the world's
best equipment
supported
locally

Sales | Service | Parts | Hire | Finance

Monitor 1575 PRO Spider Lift

1800 025 024
monitor.net.au

@MonitorAUS



V1.0 - 240718



MONITOR 1575 PRO



The Monitor 1575 PRO is an extremely compact Spider Lift for the most difficult applications. The track system expands out for extra stability and stands taller for extra ground clearance.

When retracted, it reduces to only 790 mm wide and lowers the machine to 1920 mm height for very narrow access.

Aside from its capacity of 200 kg, the basket quickly and simply detaches with only one pin for accessing very tight locations. The basket can then easily be rolled along by one person on its own castor wheels.

Uniquely, the dog-leg shaped stabilizers provide a huge amount of travel for setting up on very uneven terrain.

The Monitor 1575 PRO is also equipped with a 14 hp water-cooled twin cylinder Kubota diesel or petrol engine, auto-levelling, platform rotation, ed drive, and remote radio control and stabilization.

15M
WORKING HEIGHT





Technical Specifications

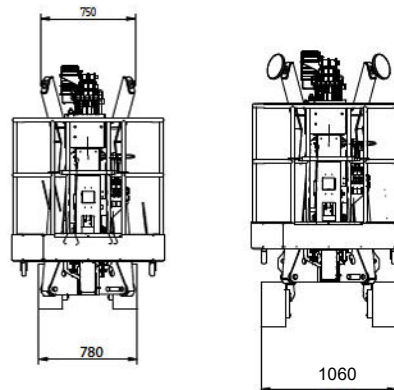
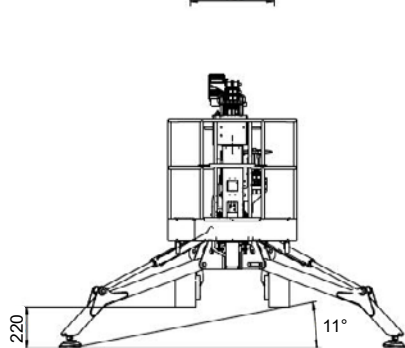
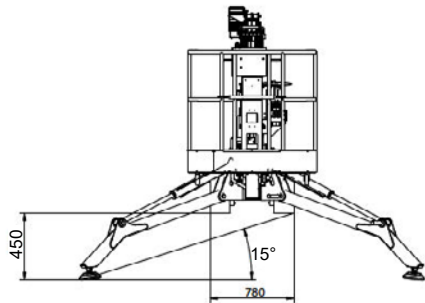
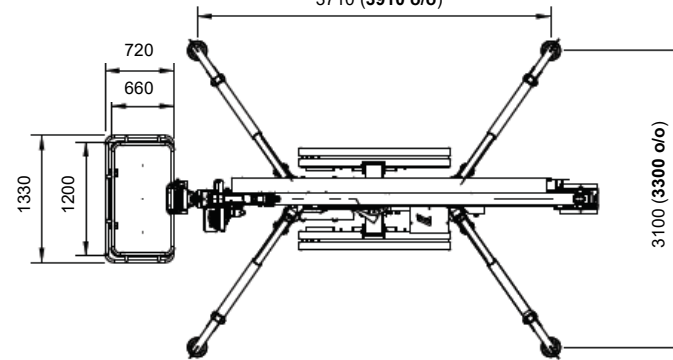
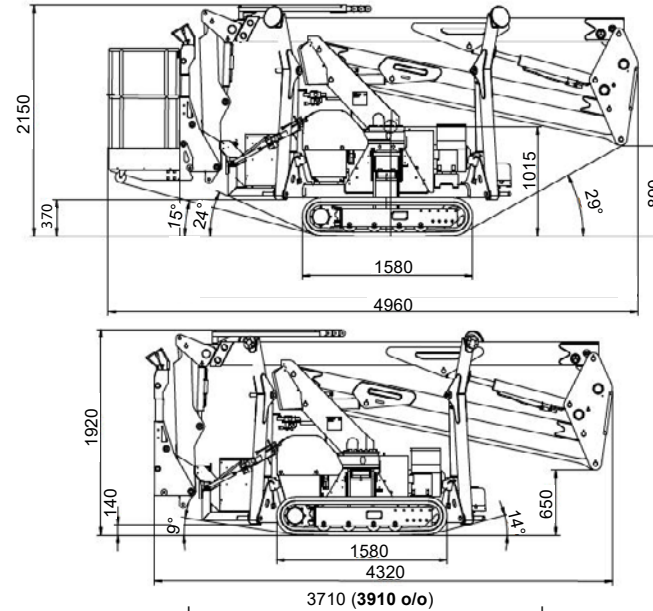
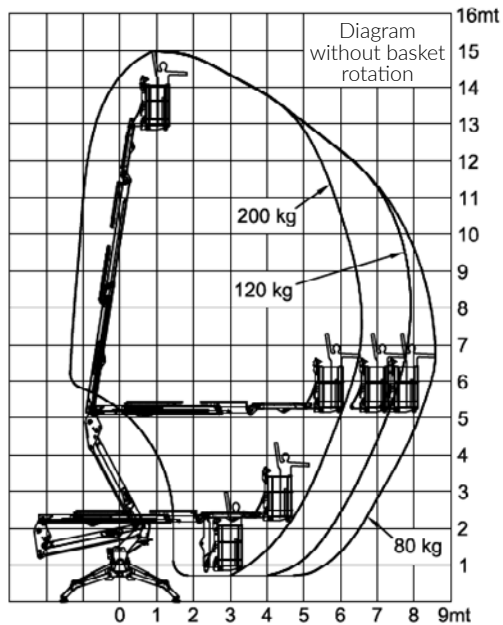

Max working height	15.00 m
Max horizontal outreach	8.50 m
Max rated capacity	200 kg
Weight: Engine + 240v	2140 kg
: Engine + Batteries	2300 kg
Turret rotation	360°
Basket rotation	140°
Ground pressure driving (approx)	38.5 kN/m ²
Max stabiliser force	14.1 kN
Max stabiliser pressure (std foot pad)	446 kN/m ²
Traffic load (live load) travelling	3.1 kN/m ²
Traffic load (live load) stabilised	1.9 kN/m ²
Auto levelling	Std
Max slope for stabilisers (no extra pads)	15°
Gradeability lengthwise	24°
Gradeability sideways	15°
Standard engine	Kubota 14 Hp Diesel
Optional engine	N/A
Dual power options	240V or Lithium
Expanding tracks	Std
Max drive speed	2.5 km/h
Radio control	Std
Electric emergency lowering	Optional

(All specs E&OE and subject to change)





zero
downtime
guarantee*



Our Locations

Branches & Service Centres



Tamworth

143 Gunnedah Rd
Tamworth NSW 2340



Sydney

49-50 Cassola Pl
Penrith NSW 2740



Melbourne

24-28 William Rd
Dandenong South VIC 3175



Brisbane

191 Magnesium Dr
Crestmead QLD 4132



Brisbane - Caboolture

2 Alta Drive
Caboolture QLD 4510



Perth

11 Reihill Rd
Maddington WA 6109

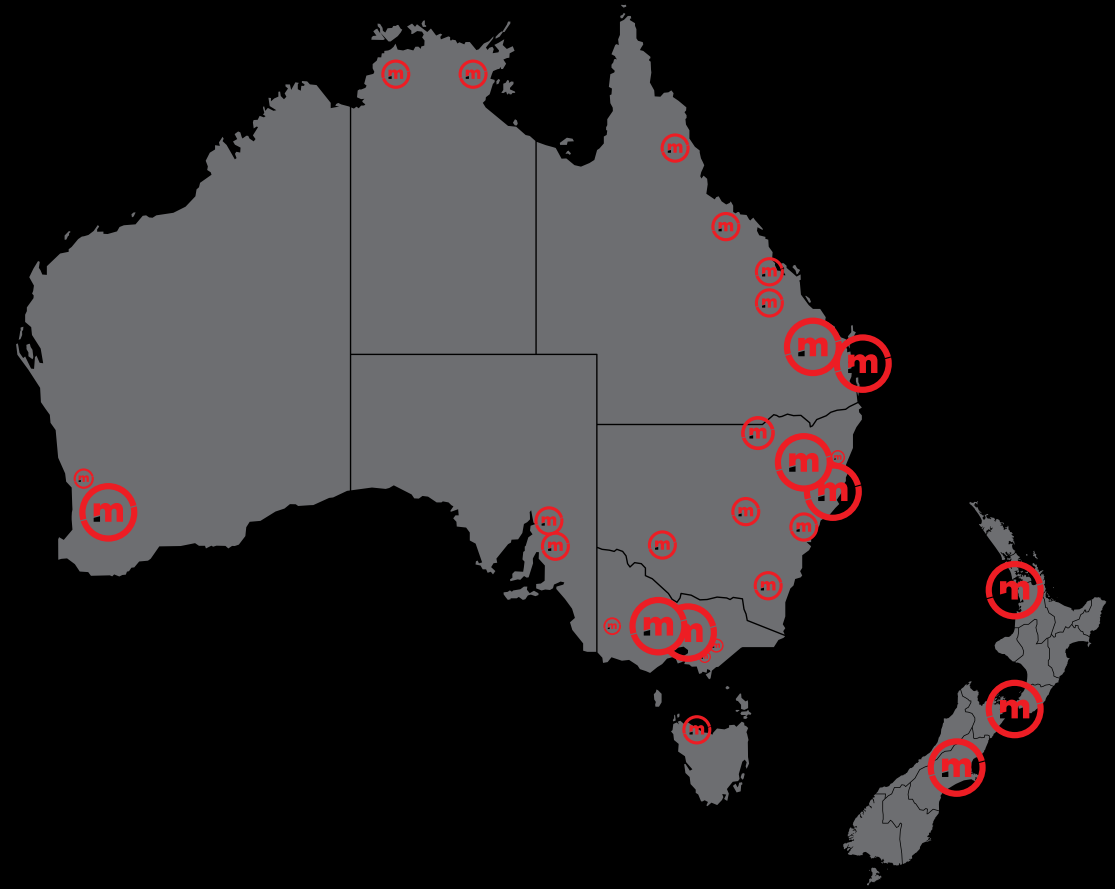

agent@monitor.net.au

1800 025 024
monitor.net.au

@MonitorAUS



monitor

the world's best equipment supported locally

Monitor 1575 PRO Spider Lift

7